



ZMR[®] Hip System



Designed to address the unpredictable

Modularity When and Where it's Needed

The *ZMR*[®] Hip System is designed to provide exceptional intraoperative flexibility and versatility to meet the unpredictable demands of revision hip surgery.

A mid-stem modular junction allows for the selection of a proximal body design to be made independent of the choice for a distal stem design.

The mid-stem design also allows for completely independent proximal/distal implant positioning and component sizing. This enables a wide variety of bone conditions to be accommodated that are often not fully revealed until the time of surgery. *ZMR* Implants are available in either a standard junction design or with an extra large junction (XL junction) for larger patients or for those patients whose femur may not provide adequate proximal support.

The *ZMR* Hip System also accommodates a number of fixation philosophies, including distal fixation, proximal porous fixation, extensive porous fixation, or a combination of distal fixation with proximal porous fixation.

Taper Lock and Compression Nut

The mid-stem junction uses a Morse-type taper connection to assure locking of the proximal body and distal stem components. The compression nut, when torqued to 15N-m (130in-lbs), provides additional security. The design of the compression nut allows for settling of the mid-stem junction without allowing the nut to become loose or back out. It keeps the interface of the locking taper junction in compression.



Version

ZMR Implant bodies are designed to provide an opportunity for version adjustment. The proximal body can be placed in any position independently of the distal stem to address various anatomic abnormalities that may be encountered without interfering with optimum distal stem placement.

Ti-Nidium Surface

The *Ti-Nidium*® Surface Hardening Process helps protect against wear at the modular taper junction of the implant.

Plasma-Sprayed Titanium Surface

All Porous bodies are plasma-sprayed with *Tivanium*® Ti-6Al-4V Alloy, which allows for biological ongrowth to aid implant stability.

Proximal Body Options

The ZMR Hip System provides the surgeon with the choice of four configurations when selecting the best proximal body for the patient. Three designs are offered in the standard junction implants and one style is available in the XL junction implants. Standard junction proximal body options include a Cone Body, Spout Body, and Calcar Body. The XL implants are discussed under another section.



With the exception of the AA Minus size bodies, a uniform core of *Titanium* Alloy plasma-sprayed porous surface, measuring 45mm in height, is featured on all three styles of standard junction proximal bodies regardless of their diameter, build-up height, or offset. The core length of the AA Minus proximal bodies is 40mm.

Neck Angle

All ZMR Implants proximal bodies, incorporate a 135° neck angle in their design.

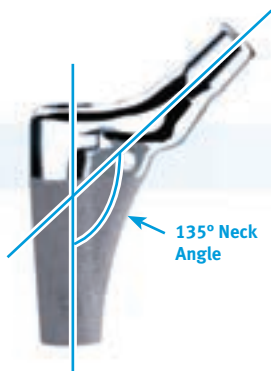

Offset

Proximal bodies are offered with multiple offset options, which allow for adjustments without changing neck angle or length.



Leg Length

Graduated build-up heights, allow for intraoperative flexibility in adjusting leg length without affecting offset.

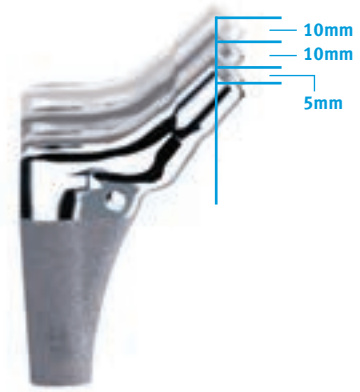

Cone Body

The Cone Body addresses those situations where maximum version control is necessary.



Calcar Body

The Calcar Body has a medial build-up to help resist subsidence and to physiologically load the proximal medial femur.



Spout Body

The Spout Body helps achieve medial fill in the proximal femur when bone deficiencies are minimal and the patient's own version can be incorporated. This contributes to initial rotational stability.



All three proximal body options may be used in conjunction with any of the distal stem choices.



Taper Stem



Porous & Porous Slotted Stems



Spline Stem

Distal Stem Options

The ZMR Hip System enables the surgeon to select from four configurations of three basic stem designs to best match the needs of the individual patient, or to address a specific preference in fixation philosophy.

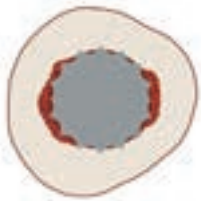

Spline Stems

Spline Stems, used in conjunction with porous proximal bodies, enable the surgeon to achieve proximal fixation with distal rotational stability. The smooth surface resists bony ingrowth while the fins, or splines, provide a diametric press fit of up to 0.5mm, giving rigid rotational control by engaging cortical bone in the femoral canal. Available in three lengths, the longer two include a coronal slot, effectively reducing distal stem stiffness while allowing for easier stem insertion. Bowed and straight stems are offered.

Porous and Porous Slotted Stems

Porous and Porous Slotted Stems, like the Spline Stems, are available in multiple lengths and diameters. Porous Stems are available in both straight and bowed options, while the Porous Slotted Stems are available as bowed only. Each of these configurations is coated with a plasma-sprayed *Titanium* Alloy for biological fixation. When used with a porous proximal body, the surgeon can expect extensive fixation capabilities.

Taper Stems

Taper Stems are available in three straight lengths with multiple diameters in each. Straight stems assist ease of insertion, encourage three-point fixation, and enable the surgeon to bypass bone defects. An anterior bevel further makes stem insertion easier by accommodating the natural anterior bow of the femur while helping to prevent distal impingement and perforation of the anterior cortex.

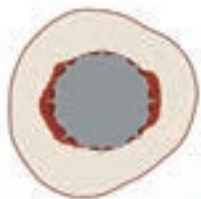

ZMR Taper Stems incorporate a 3.5° distal taper geometry which promotes axial load transfer and resistance to subsidence. Splines with 0.75mm of press fit per spline provide rigid rotational control by engaging the bone in the femoral canal. Stability is further enhanced by the roughened, corundumized *Titanium* Alloy substrate which allows for bone ongrowth.

Anterior Bevel

The anterior bevel is designed to make stem insertion easier by accommodating the natural bow of the femur, and to help prevent impingement of the anterior cortex with longer stems.



Taper Stems

A consistent 3.5° taper geometry over the distal 105mm of the stem promotes axial load transfer and resistance to subsidence while 0.75mm splines, equaling a 1.5mm press fit, provide unyielding rotational stability. Implant stability is further enhanced by the corundumized surface.

An anterior bevel eases implant insertion by accommodating the anterior bow of the femur and helps to reduce the potential for distal impingement of the anterior cortex. Three stem lengths, 135mm, 185mm, and 235mm are offered in eight diameters.



Porous and Porous Slotted Stems

Straight and bowed stems are available in up to four lengths and 10 diameters to optimize patient fit. The plasma-sprayed *Titanium* Alloy surface results in a 0.5mm “scratch fit” per side (1mm total press fit) for rotational and axial stability while encouraging biological fixation.



Spline Stems

A diametric press fit of up to 0.5mm per spline (1mm total press fit) gives these straight or bowed stems rigid rotational control. Coronal slots on the two longest lengths reduce distal stem stiffness and allow for easier insertion into the femur. Up to three stem lengths and 10 diameters help to optimize patient fit.



Any distal stem configuration may be used in conjunction with any of the proximal body choices.



Cone Body



Calcar Body



Spout Body

Corundumized Stem Surface

The roughened ($R_a = 4\mu\text{m}-7\mu\text{m}/158\mu\text{in}-276\mu\text{in}$) implant surface finish maintains the high strength of the *Titanium* Alloy substrate and allows for biological ongrowth to aid implant stability.

Ti-Nidium Surface Hardening

Every distal implant undergoes a *Ti-Nidium* Surface Hardening Process which helps to protect against wear at the modular taper junction.

ZMR XL Implants

In any hip replacement surgery, proximal support for the implant is desirable. However, especially in revision hip surgery, the surgeon may not always be able to achieve optimum proximal support for the femoral component. The *ZMR XL Hip System**, with strength characteristics that more than double the strength of a standard *ZMR Implant*, has been developed to accommodate those cases in which proximal support cannot be achieved. However, as with any femoral implant, if proximal support is not obtained, the patient should be warned of an increased risk for potential fatigue fracture, even when the *ZMR XL System* construct is utilized.¹

A selection of eight proximal body sizes provides length and offset choices to meet individual patient demands. Their roughened corundumized surface allows for bone ongrowth which may enhance implant stability. Distally, there are two stem options to choose from, a porous and a taper. The design characteristics of the XL Stems mimic the features of the standard junction implants.



Taper Stem Options

A consistent 3.5° taper geometry over the distal 105mm of the stem promotes axial load transfer and resistance to subsidence while 0.75mm splines, equaling a 1.5mm press fit, provide unyielding rotational stability. Implant stability is further enhanced by the corundumized surface. An anterior bevel eases implant insertion by accommodating the anterior bow of the femur, and helps to reduce the potential for distal impingement of the anterior cortex. Three stem lengths, 135mm, 185mm and 235mm are offered in eight diameters.



Porous Stem Options

Straight and bowed stems are available in a 170mm length. Bowed stems are also offered in 220mm and 260mm lengths, and all lengths are provided in seven diameters to optimize patient fit. The plasma-sprayed *Titanium* Alloy surface results in a 0.5mm “scratch fit” per side (1mm total press fit) for rotational and axial stability while encouraging biological fixation.

* For femurs with inadequate proximal support, the *ZMR XL Hip System* should be used in combination with proximal allograft struts or other adjunctive reinforcement techniques.

Proximal Body Heights

All XL Bodies are a “Cone” design. There are four height options of 78mm, 83mm, 93mm, and 103mm available which allow for intraoperative flexibility in adjusting leg length, and each length has a standard and extended offset option. Another feature which is unique to the XL Body is the lateral relief on the distal portion of the body. Referred to as a cutout, this area further enhances the fatigue strength at the mid-stem junction. A roughened corundumized surface allows for bone ongrowth which may aid implant stability.

103mm
93mm
83mm
78mm

Cutout

Junction Testing

The XL mid-stem junction has been tested in a manner simulating a lack of proximal support.²



Offset

An extended offset body option provides for increased offset without changing the component neck angle or leg length.



ZMR Cone Bodies

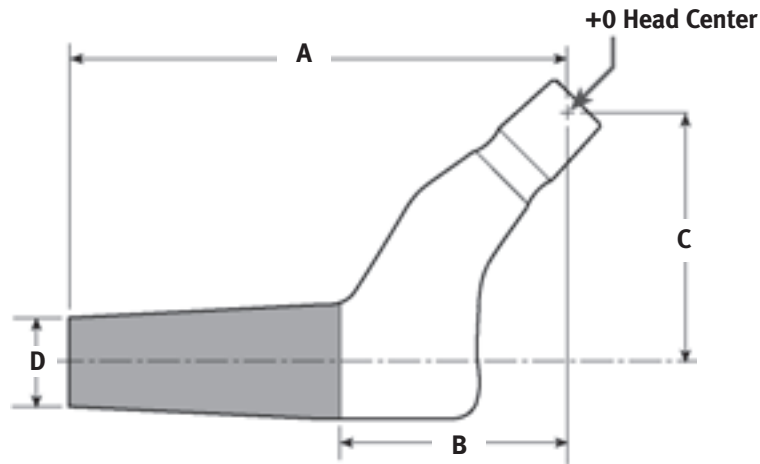

Prod. No.	Description	A Body Length (mm)	B Calcar Height (mm)	C Offset (mm) When Head/Neck Component Selected is:					D Body Size w/Plasma (mm)
				-3.5	+0	+3.5	+7	+10.5	
00-9942-016-35	Cone AA- Body, 36 x 35mm Neck	75	35	33.5	36	38.5	41	43.5	16.6
00-9943-016-35	Cone AA- Body, 40 x 35mm Neck	75	35	37.5	40	42.5	45	47.5	16.6
00-9941-016-35	Cone AA Body, 36 x 35mm Neck	80	35	33.5	36	38.5	41	43.5	16.6
00-9996-016-35	Cone AA Body, 40 x 35mm Neck	80	35	37.5	40	42.5	45	47.5	16.6
00-9996-017-35	Cone A Body, 40 x 35mm Neck	80	35	37.5	40	42.5	45	47.5	17.7
00-9993-017-35	Cone A Body, 46 x 35mm Neck	80	35	43.5	46	48.5	51	53.5	17.7
00-9996-018-35	Cone B Body, 40 x 35mm Neck	80	35	37.5	40	42.5	45	47.5	18.9
00-9993-018-35	Cone B Body, 46 x 35mm Neck	80	35	43.5	46	48.5	51	53.5	18.9
00-9996-019-35	Cone C Body, 40 x 35mm Neck	80	35	37.5	40	42.5	45	47.5	20.0
00-9993-019-35	Cone C Body, 46 x 35mm Neck	80	35	43.5	46	48.5	51	53.5	20.0
00-9996-020-35	Cone D Body, 40 x 35mm Neck	80	35	37.5	40	42.5	45	47.5	21.2
00-9993-020-35	Cone D Body, 46 x 35mm Neck	80	35	43.5	46	48.5	51	53.5	21.2
00-9996-021-35	Cone E Body, 40 x 35mm Neck	80	35	37.5	40	42.5	45	47.5	22.5
00-9993-021-35	Cone E Body, 46 x 35mm Neck	80	35	43.5	46	48.5	51	53.5	22.5
00-9996-023-35	Cone F Body, 40 x 35mm Neck	80	35	37.5	40	42.5	45	47.5	23.7
00-9993-023-35	Cone F Body, 46 x 35mm Neck	80	35	43.5	46	48.5	51	53.5	23.7
00-9996-017-45	Cone A Body, 40 x 45mm Neck	90	45	37.5	40	42.5	45	47.5	17.7
00-9993-017-45	Cone A Body, 46 x 45mm Neck	90	45	43.5	46	48.5	51	53.5	17.7
00-9996-018-45	Cone B Body, 40 x 45mm Neck	90	45	37.5	40	42.5	45	47.5	18.9
00-9993-018-45	Cone B Body, 46 x 45mm Neck	90	45	43.5	46	48.5	51	53.5	18.9
00-9996-019-45	Cone C Body, 40 x 45mm Neck	90	45	37.5	40	42.5	45	47.5	20.0
00-9993-019-45	Cone C Body, 46 x 45mm Neck	90	45	43.5	46	48.5	51	53.5	20.0
00-9993-020-45	Cone D Body, 46 x 45mm Neck	90	45	43.5	46	48.5	51	53.5	21.2
00-9993-021-45	Cone E Body, 46 x 45mm Neck	90	45	43.5	46	48.5	51	53.5	22.5
00-9993-023-45	Cone F Body, 46 x 45mm Neck	90	45	43.5	46	48.5	51	53.5	23.7
00-9996-017-55	Cone A Body, 40 x 55mm Neck	100	55	37.5	40	42.5	45	47.5	17.7
00-9993-017-55	Cone A Body, 46 x 55mm Neck	100	55	43.5	46	48.5	51	53.5	17.7
00-9996-018-55	Cone B Body, 40 x 55mm Neck	100	55	37.5	40	42.5	45	47.5	18.9
00-9993-018-55	Cone B Body, 46 x 55mm Neck	100	55	43.5	46	48.5	51	53.5	18.9
00-9996-019-55	Cone C Body, 40 x 55mm Neck	100	55	37.5	40	42.5	45	47.5	20.0
00-9993-019-55	Cone C Body, 46 x 55mm Neck	100	55	43.5	46	48.5	51	53.5	20.0
00-9993-020-55	Cone D Body, 46 x 55mm Neck	100	55	43.5	46	48.5	51	53.5	21.2
00-9993-021-55	Cone E Body, 46 x 55mm Neck	100	55	43.5	46	48.5	51	53.5	22.5
00-9993-023-55	Cone F Body, 46 x 55mm Neck	100	55	43.5	46	48.5	51	53.5	23.7

ZMR Calcar Bodies

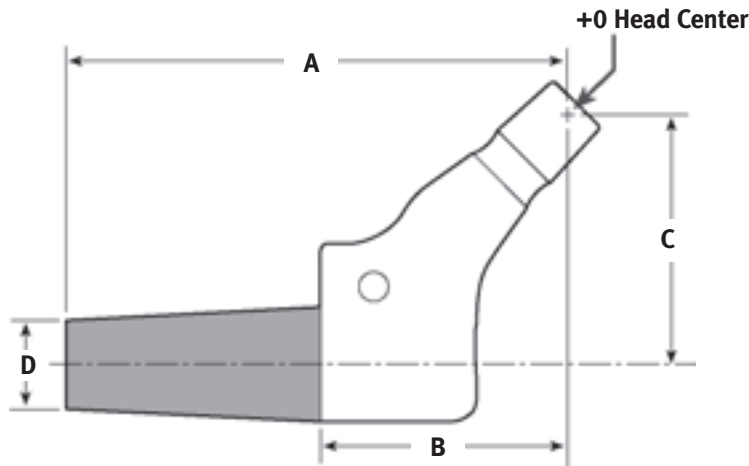

Prod. No.	Description	A Body Length (mm)	B Calcar Height (mm)	C Offset (mm) When Head/Neck Component Selected is:					D Body Size w/Plasma (mm)
				-3.5	+0	+3.5	+7	+10.5	
00-9947-016-35	Calcar AA- Body, 36 x 35mm Neck	75	35	33.5	36	38.5	41	43.5	16.6
00-9948-016-35	Calcar AA- Body, 40 x 35mm Neck	75	35	37.5	40	42.5	45	47.5	16.6
00-9946-016-35	Calcar AA Body, 36 x 35mm Neck	80	35	33.5	36	38.5	41	43.5	16.6
00-9998-016-35	Calcar AA Body, 40 x 35mm Neck	80	35	37.5	40	42.5	45	47.5	16.6
00-9998-017-35	Calcar A Body, 40 x 35mm Neck	80	35	37.5	40	42.5	45	47.5	17.7
00-9998-018-35	Calcar B Body, 40 x 35mm Neck	80	35	37.5	40	42.5	45	47.5	18.9
00-9998-019-35	Calcar C Body, 40 x 35mm Neck	80	35	37.5	40	42.5	45	47.5	20.0
00-9998-017-45	Calcar A Body, 40 x 45mm Neck	90	45	37.5	40	42.5	45	47.5	17.7
00-9994-017-45	Calcar A Body, 46 x 45mm Neck	90	45	43.5	46	48.5	51	53.5	17.7
00-9998-018-45	Calcar B Body, 40 x 45mm Neck	90	45	37.5	40	42.5	45	47.5	18.9
00-9994-018-45	Calcar B Body, 46 x 45mm Neck	90	45	43.5	46	48.5	51	53.5	18.9
00-9998-019-45	Calcar C Body, 40 x 45mm Neck	90	45	37.5	40	42.5	45	47.5	20.0
00-9994-019-45	Calcar C Body, 46 x 45mm Neck	90	45	43.5	46	48.5	51	53.5	20.0
00-9994-020-45	Calcar D Body, 46 x 45mm Neck	90	45	43.5	46	48.5	51	53.5	21.2
00-9994-021-45	Calcar E Body, 46 x 45mm Neck	90	45	43.5	46	48.5	51	53.5	22.5
00-9994-023-45	Calcar F Body, 46 x 45mm Neck	90	45	43.5	46	48.5	51	53.5	23.7
00-9998-017-55	Calcar A Body, 40 x 55mm Neck	100	55	37.5	40	42.5	45	47.5	17.7
00-9994-017-55	Calcar A Body, 46 x 55mm Neck	100	55	43.5	46	48.5	51	53.5	17.7
00-9998-018-55	Calcar B Body, 40 x 55mm Neck	100	55	37.5	40	42.5	45	47.5	18.9
00-9994-018-55	Calcar B Body, 46 x 55mm Neck	100	55	43.5	46	48.5	51	53.5	18.9
00-9998-019-55	Calcar C Body, 40 x 55mm Neck	100	55	37.5	40	42.5	45	47.5	20.0
00-9994-019-55	Calcar C Body, 46 x 55mm Neck	100	55	43.5	46	48.5	51	53.5	20.0
00-9994-020-55	Calcar D Body, 46 x 55mm Neck	100	55	43.5	46	48.5	51	53.5	21.2
00-9994-021-55	Calcar E Body, 46 x 55mm Neck	100	55	43.5	46	48.5	51	53.5	22.5
00-9994-023-55	Calcar F Body, 46 x 55mm Neck	100	55	43.5	46	48.5	51	53.5	23.7

ZMR Spout Bodies

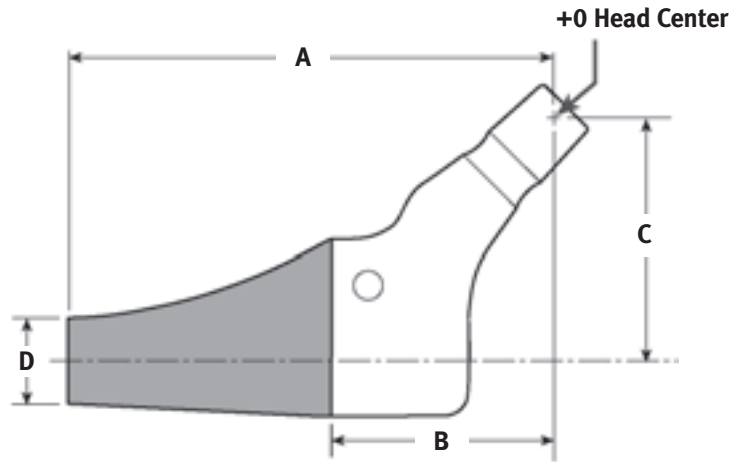

Prod. No.	Description	A Body Length (mm)	B Calcar Height (mm)	C Offset (mm) When Head/Neck Component Selected is:					D Body Size w/Plasma (mm)
				-3.5	+0	+3.5	+7	+10.5	
00-9940-016-40	Spout AA- Body, 40 x 35mm Neck	75	35	37.5	40	42.5	45	47.5	16.6
00-9990-016-36	Spout AA Body, 36 x 35mm Neck	80	35	33.5	36	38.5	41	43.5	16.6
00-9990-016-40	Spout AA Body, 40 x 35mm Neck	80	35	37.5	40	42.5	45	47.5	16.6
00-9990-017-40	Spout A Body, 40 x 35mm Neck	80	35	37.5	40	42.5	45	47.5	17.7
00-9990-017-46	Spout A Body, 46 x 35mm Neck	80	35	43.5	46	48.5	51	53.5	17.7
00-9990-018-40	Spout B Body, 40 x 35mm Neck	80	35	37.5	40	42.5	45	47.5	18.9
00-9990-018-46	Spout B Body, 46 x 35mm Neck	80	35	43.5	46	48.5	51	53.5	18.9
00-9990-019-40	Spout C Body, 40 x 35mm Neck	80	35	37.5	40	42.5	45	47.5	20.0
00-9990-019-46	Spout C Body, 46 x 35mm Neck	80	35	43.5	46	48.5	51	53.5	20.0
00-9990-020-40	Spout D Body, 40 x 35mm Neck	80	35	37.5	40	42.5	45	47.5	21.2
00-9990-020-46	Spout D Body, 46 x 35mm Neck	80	35	43.5	46	48.5	51	53.5	21.2
00-9990-021-40	Spout E Body, 40 x 35mm Neck	80	35	37.5	40	42.5	45	47.5	22.5
00-9990-021-46	Spout E Body, 46 x 35mm Neck	80	35	43.5	46	48.5	51	53.5	22.5
00-9990-023-40	Spout F Body, 40 x 35mm Neck	80	35	37.5	40	42.5	45	47.5	23.7
00-9990-023-46	Spout F Body, 46 x 35mm Neck	80	35	43.5	46	48.5	51	53.5	23.7
00-9997-017-45	Spout A Body, 40 x 45mm Neck	90	45	37.5	40	42.5	45	47.5	17.7
00-9991-017-45	Spout A Body, 46 x 45mm Neck	90	45	43.5	46	48.5	51	53.5	17.7
00-9997-018-45	Spout B Body, 40 x 45mm Neck	90	45	37.5	40	42.5	45	47.5	18.9
00-9991-018-45	Spout B Body, 46 x 45mm Neck	90	45	43.5	46	48.5	51	53.5	18.9
00-9997-019-45	Spout C Body, 40 x 45mm Neck	90	45	37.5	40	42.5	45	47.5	20.0
00-9991-019-45	Spout C Body, 46 x 45mm Neck	90	45	43.5	46	48.5	51	53.5	20.0
00-9991-020-45	Spout D Body, 46 x 45mm Neck	90	45	43.5	46	48.5	51	53.5	21.2
00-9991-021-45	Spout E Body, 46 x 45mm Neck	90	45	43.5	46	48.5	51	53.5	22.5
00-9991-023-45	Spout F Body, 46 x 45mm Neck	90	45	43.5	46	48.5	51	53.5	23.7
00-9997-017-55	Spout A Body, 40 x 55mm Neck	100	55	37.5	40	42.5	45	47.5	17.7
00-9991-017-55	Spout A Body, 46 x 55mm Neck	100	55	43.5	46	48.5	51	53.5	17.7
00-9997-018-55	Spout B Body, 40 x 55mm Neck	100	55	37.5	40	42.5	45	47.5	18.9
00-9991-018-55	Spout B Body, 46 x 55mm Neck	100	55	43.5	46	48.5	51	53.5	18.9
00-9997-019-55	Spout C Body, 40 x 55mm Neck	100	55	37.5	40	42.5	45	47.5	20.0
00-9991-019-55	Spout C Body, 46 x 55mm Neck	100	55	43.5	46	48.5	51	53.5	20.0
00-9991-020-55	Spout D Body, 46 x 55mm Neck	100	55	43.5	46	48.5	51	53.5	21.2
00-9991-021-55	Spout E Body, 46 x 55mm Neck	100	55	43.5	46	48.5	51	53.5	22.5
00-9991-023-55	Spout F Body, 46 x 55mm Neck	100	55	43.5	46	48.5	51	53.5	23.7

ZMR Stems

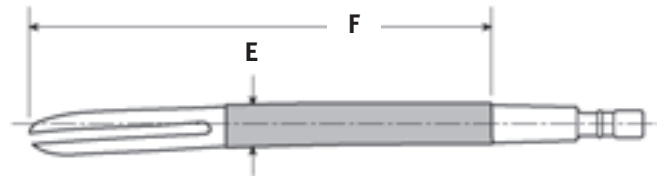
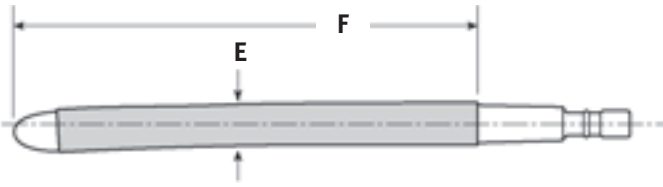

Porous Stems

Prod. No.	Description	E Stem Dia. (mm)	F Stem Length (mm)
00-9981-120-21	Porous Stem, 12.0 x 115mm, Straight	12.0	115
00-9981-120-22	Porous Stem, 12.0 x 170mm, Straight	12.0	170
00-9981-120-32	Porous Stem, 12.0 x 170mm, Bow	12.0	170
00-9981-135-21	Porous Stem, 13.5 x 115mm, Straight	13.5	115
00-9981-135-22	Porous Stem, 13.5 x 170mm, Straight	13.5	170
00-9981-135-32	Porous Stem, 13.5 x 170mm, Bow	13.5	170
00-9981-135-33	Porous Stem, 13.5 x 220mm, Bow	13.5	220
00-9981-150-21	Porous Stem, 15.0 x 115mm, Straight	15.0	115
00-9981-150-22	Porous Stem, 15.0 x 170mm, Straight	15.0	170
00-9981-150-32	Porous Stem, 15.0 x 170mm, Bow	15.0	170
00-9981-150-33	Porous Stem, 15.0 x 220mm, Bow	15.0	220
00-9981-165-21	Porous Stem, 16.5 x 115mm, Straight	16.5	115
00-9981-165-22	Porous Stem, 16.5 x 170mm, Straight	16.5	170
00-9981-165-32	Porous Stem, 16.5 x 170mm, Bow	16.5	170
00-9981-165-33	Porous Stem, 16.5 x 220mm, Bow	16.5	220
00-9981-180-21	Porous Stem, 18.0 x 115mm, Straight	18.0	115
00-9981-180-22	Porous Stem, 18.0 x 170mm, Straight	18.0	170
00-9981-180-32	Porous Stem, 18.0 x 170mm, Bow	18.0	170
00-9981-180-33	Porous Stem, 18.0 x 220mm, Bow	18.0	220
00-9981-195-21	Porous Stem, 19.5 x 115mm, Straight	19.5	115
00-9981-195-22	Porous Stem, 19.5 x 170mm, Straight	19.5	170
00-9981-195-32	Porous Stem, 19.5 x 170mm, Bow	19.5	170
00-9981-195-33	Porous Stem, 19.5 x 220mm, Bow	19.5	220
00-9981-210-22	Porous Stem, 21.0 x 170mm, Straight	21.0	170
00-9981-210-32	Porous Stem, 21.0 x 170mm, Bow	21.0	170
00-9981-210-33	Porous Stem, 21.0 x 220mm, Bow	21.0	220
00-9981-225-22	Porous Stem, 22.5 x 170mm, Straight	22.5	170
00-9981-225-32	Porous Stem, 22.5 x 170mm, Bow	22.5	170
00-9981-225-33	Porous Stem, 22.5 x 220mm, Bow	22.5	220
00-9981-240-22	Porous Stem, 24.0 x 170mm, Straight	24.0	170
00-9981-240-32	Porous Stem, 24.0 x 170mm, Bow	24.0	170
00-9981-240-33	Porous Stem, 24.0 x 220mm, Bow	24.0	220
00-9981-255-22	Porous Stem, 25.5 x 170mm, Straight	25.5	170
00-9981-255-32	Porous Stem, 25.5 x 170mm, Bow	25.5	170
00-9981-255-33	Porous Stem, 25.5 x 220mm, Bow	25.5	220

Slotted Porous Stems

Prod. No.	Description	E Stem Dia. (mm)	F Stem Length (mm)
00-9983-120-32	Slotted Porous Stem, 12.0 x 170mm, Bow	12.0	170
00-9983-135-32	Slotted Porous Stem, 13.5 x 170mm, Bow	13.5	170
00-9983-135-33	Slotted Porous Stem, 13.5 x 220mm, Bow	13.5	220
00-9983-150-32	Slotted Porous Stem, 15.0 x 170mm, Bow	15.0	170
00-9983-150-33	Slotted Porous Stem, 15.0 x 220mm, Bow	15.0	220
00-9983-150-34	Slotted Porous Stem, 15.0 x 260mm, Bow	15.0	260
00-9983-165-32	Slotted Porous Stem, 16.5 x 170mm, Bow	16.5	170
00-9983-165-33	Slotted Porous Stem, 16.5 x 220mm, Bow	16.5	220
00-9983-165-34	Slotted Porous Stem, 16.5 x 260mm, Bow	16.5	260
00-9983-180-32	Slotted Porous Stem, 18.0 x 170mm, Bow	18.0	170
00-9983-180-33	Slotted Porous Stem, 18.0 x 220mm, Bow	18.0	220
00-9983-180-34	Slotted Porous Stem, 18.0 x 260mm, Bow	18.0	260
00-9983-195-32	Slotted Porous Stem, 19.5 x 170mm, Bow	19.5	170
00-9983-195-33	Slotted Porous Stem, 19.5 x 220mm, Bow	19.5	220
00-9983-195-34	Slotted Porous Stem, 19.5 x 260mm, Bow	19.5	260
00-9983-210-32	Slotted Porous Stem, 21.0 x 170mm, Bow	21.0	170
00-9983-210-33	Slotted Porous Stem, 21.0 x 220mm, Bow	21.0	220
00-9983-210-34	Slotted Porous Stem, 21.0 x 260mm, Bow	21.0	260
00-9983-225-32	Slotted Porous Stem, 22.5 x 170mm, Bow	22.5	170
00-9983-225-33	Slotted Porous Stem, 22.5 x 220mm, Bow	22.5	220
00-9983-225-34	Slotted Porous Stem, 22.5 x 260mm, Bow	22.5	260
00-9983-240-32	Slotted Porous Stem, 24.0 x 170mm, Bow	24.0	170
00-9983-240-33	Slotted Porous Stem, 24.0 x 220mm, Bow	24.0	220
00-9983-240-34	Slotted Porous Stem, 24.0 x 260mm, Bow	24.0	260
00-9983-255-32	Slotted Porous Stem, 25.5 x 170mm, Bow	25.5	170
00-9983-255-33	Slotted Porous Stem, 25.5 x 220mm, Bow	25.5	220
00-9983-255-34	Slotted Porous Stem, 25.5 x 260mm, Bow	25.5	260

ZMR Stems

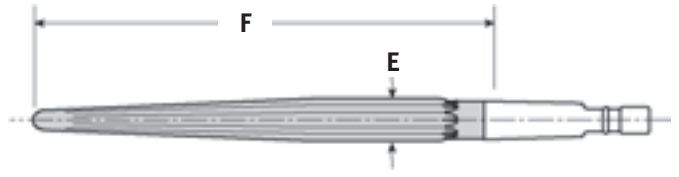
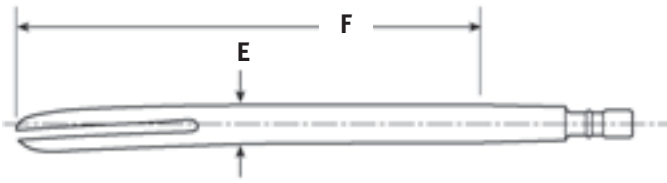

Spline Stems

Prod. No.	Description	E Stem Dia. (mm)	F Stem Length (mm)
00-9980-120-21	Spline Stem, 12.0 x 115mm, Straight	12.0	115
00-9980-120-22	Spline Stem, 12.0 x 170mm, Straight	12.0	170
00-9980-120-32	Spline Stem, 12.0 x 170mm, Bow	12.0	170
00-9980-135-21	Spline Stem, 13.5 x 115mm, Straight	13.5	115
00-9980-135-22	Spline Stem, 13.5 x 170mm, Straight	13.5	170
00-9980-135-32	Spline Stem, 13.5 x 170mm, Bow	13.5	170
00-9980-135-33	Spline Stem, 13.5 x 220mm, Bow	13.5	220
00-9980-150-21	Spline Stem, 15.0 x 115mm, Straight	15.0	115
00-9980-150-22	Spline Stem, 15.0 x 170mm, Straight	15.0	170
00-9980-150-32	Spline Stem, 15.0 x 170mm, Bow	15.0	170
00-9980-150-33	Spline Stem, 15.0 x 220mm, Bow	15.0	220
00-9980-165-21	Spline Stem, 16.5 x 115mm, Straight	16.5	115
00-9980-165-22	Spline Stem, 16.5 x 170mm, Straight	16.5	170
00-9980-165-32	Spline Stem, 16.5 x 170mm, Bow	16.5	170
00-9980-165-33	Spline Stem, 16.5 x 220mm, Bow	16.5	220
00-9980-180-21	Spline Stem, 18.0 x 115mm, Straight	18.0	115
00-9980-180-22	Spline Stem, 18.0 x 170mm, Straight	18.0	170
00-9980-180-32	Spline Stem, 18.0 x 170mm, Bow	18.0	170
00-9980-180-33	Spline Stem, 18.0 x 220mm, Bow	18.0	220
00-9980-195-21	Spline Stem, 19.5 x 115mm, Straight	19.5	115
00-9980-195-22	Spline Stem, 19.5 x 170mm, Straight	19.5	170
00-9980-195-32	Spline Stem, 19.5 x 170mm, Bow	19.5	170
00-9980-195-33	Spline Stem, 19.5 x 220mm, Bow	19.5	220
00-9980-210-22	Spline Stem, 21.0 x 170mm, Straight	21.0	170
00-9980-210-32	Spline Stem, 21.0 x 170mm, Bow	21.0	170
00-9980-210-33	Spline Stem, 21.0 x 220mm, Bow	21.0	220
00-9980-225-22	Spline Stem, 22.5 x 170mm, Straight	22.5	170
00-9980-225-32	Spline Stem, 22.5 x 170mm, Bow	22.5	170
00-9980-225-33	Spline Stem, 22.5 x 220mm, Bow	22.5	220
00-9980-240-22	Spline Stem, 24.0 x 170mm, Straight	24.0	170
00-9980-240-32	Spline Stem, 24.0 x 170mm, Bow	24.0	170
00-9980-240-33	Spline Stem, 24.0 x 220mm, Bow	24.0	220
00-9980-255-22	Spline Stem, 25.5 x 170mm, Straight	25.5	170
00-9980-255-32	Spline Stem, 25.5 x 170mm, Bow	25.5	170
00-9980-255-33	Spline Stem, 25.5 x 220mm, Bow	25.5	220

Taper Stems

Prod. No.	Description	E Stem Diameter (mm)	F Stem Length (mm)
00-9982-014-13	Taper Stem, 14mm x 135mm	14	135
00-9982-014-18	Taper Stem, 14mm x 185mm	14	185
00-9982-015-13	Taper Stem, 15mm x 135mm	15	135
00-9982-015-18	Taper Stem, 15mm x 185mm	15	185
00-9982-016-13	Taper Stem, 16mm x 135mm	16	135
00-9982-016-18	Taper Stem, 16mm x 185mm	16	185
00-9982-016-23	Taper Stem, 16mm x 235mm	16	235
00-9982-017-13	Taper Stem, 17mm x 135mm	17	135
00-9982-017-18	Taper Stem, 17mm x 185mm	17	185
00-9982-017-23	Taper Stem, 17mm x 235mm	17	235
00-9982-018-13	Taper Stem, 18mm x 135mm	18	135
00-9982-018-18	Taper Stem, 18mm x 185mm	18	185
00-9982-018-23	Taper Stem, 18mm x 235mm	18	235
00-9982-019-13	Taper Stem, 19mm x 135mm	19	135
00-9982-019-18	Taper Stem, 19mm x 185mm	19	185
00-9982-019-23	Taper Stem, 19mm x 235mm	19	235
00-9982-020-18	Taper Stem, 20mm x 185mm	20	185
00-9982-020-23	Taper Stem, 20mm x 235mm	20	235
00-9982-022-18	Taper Stem, 22mm x 185mm	22	185
00-9982-022-23	Taper Stem, 22mm x 235mm	22	235

ZMR Porous Hip

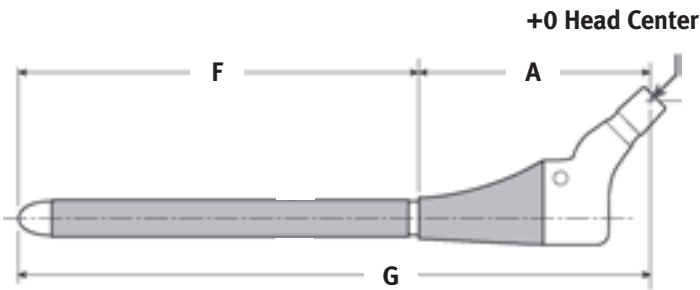

ZMR Taper Hip

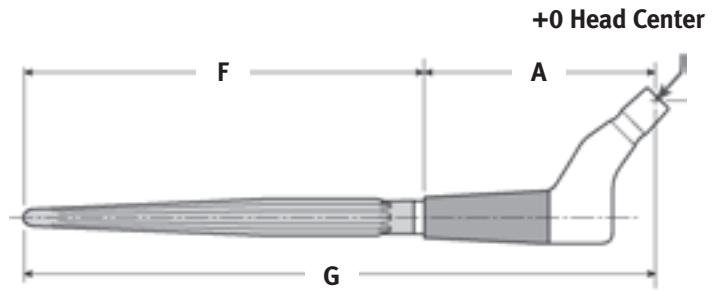

Assembled Implant Length

A Body Length (mm)	+	F Stem Length (mm)	=	G Implant Length (mm)
75		115		190
75		135		210
75		170		245
75		185		260
75		220		295
75		235		310
75		260		335
80		115		195
80		135		215
80		170		250
80		185		265
80		220		300
80		235		315
80		260		340
90		115		205
90		135		225
90		170		260
90		185		275
90		220		310
90		235		325
90		260		350
100		115		215
100		135		235
100		170		270
100		185		285
100		220		320
100		235		335
100		260		360

Instrumentation*

Prod. No.	Description
00-9961-000-02	Bowed Provisional Stem Set*
00-9961-000-03	Straight Provisional Stem Set*
00-9961-000-04	Macro Bowed Provisional Stem Set*
00-9970-000-01	Spout Provisional Body Set*
00-9970-000-02	Cone Provisional Body Set*
00-9970-000-03	Calcar Provisional Body Set*
00-9975-000-06	Straight Reamer Set #1*
00-9975-000-07	Straight Reamer Set #2*
00-9975-000-11	Flexible Reamer Set*
00-9975-000-39	Proximal Preparation Instrument Set #1*
00-9975-000-40	Proximal Preparation Instrument Set #2*
00-9965-000-02	Crossover Instrument Set*
00-9970-000-01	Spout Provisional Body Set*
00-9970-000-02	Cone Provisional Body Set*
00-9970-000-03	Calcar Provisional Body Set*
00-9972-000-00	Taper Provisional Set*
00-9975-000-30	Taper Assembly Instrument Set*
00-9975-000-45	General Instrument Set*
00-9975-099-00	Case Lid

* Set includes case and contents without the 00-9975-099-00 Case Lid.
The Case Lid must be ordered separately.

Compression Nut**

Prod. No.	Description
00-9982-099-02	Junction Nut**

** Compression nuts are also packed with distal stems.

ZMR XL Bodies

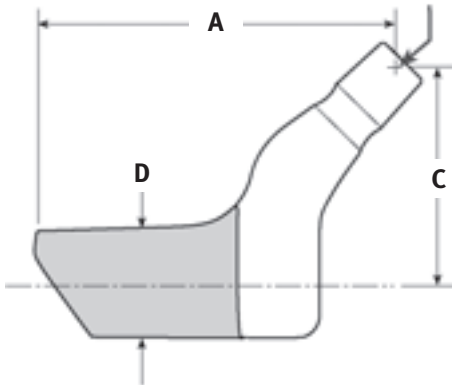

Prod. No.	Description	A Body Length (mm)	Reference Standard ZMR Body Size	C Offset (mm) When Head/Neck Component Selected is:					D Body Size (mm)
				-3.5	+0	+3.5	+7	+10.5	
00-9923-078-40	78mm, XL Body, Std Offset	78	AA-	37.5	40	42.5	45	47.5	23.0
00-9923-083-40	83mm, XL Body, Std Offset	83	35	37.5	40	42.5	45	47.5	23.0
00-9923-093-40	93mm, XL Body, Std Offset	93	45	37.5	40	42.5	45	47.5	23.0
00-9923-103-40	103mm, XL Body, Std Offset	103	55	37.5	40	42.5	45	47.5	23.0
00-9923-078-45	78mm, XL Body, Ext Offset	78	AA-	42.5	45	47.5	50	52.5	23.0
00-9923-083-45	83mm, XL Body, Ext Offset	83	35	42.5	45	47.5	50	52.5	23.0
00-9923-093-45	93mm, XL Body, Ext Offset	93	45	42.5	45	47.5	50	52.5	23.0
00-9923-103-45	103mm, XL Body, Ext Offset	103	55	42.5	45	47.5	50	52.5	23.0

ZMR XL Stems

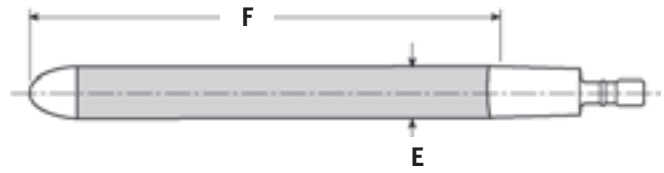
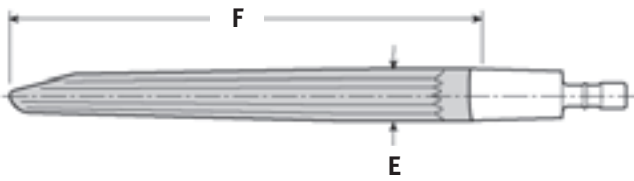

XL Taper Stems

Prod. No.	Description	E Stem Dia. (mm)	F Stem Length (mm)
00-9922-017-13	XL Taper Stem, 17mm X 135mm	17	135
00-9922-017-18	XL Taper Stem, 17mm X 185mm	17	185
00-9922-017-23	XL Taper Stem, 17mm X 235mm	17	235
00-9922-018-13	XL Taper Stem, 18mm X 135mm	18	135
00-9922-018-18	XL Taper Stem, 18mm X 185mm	18	185
00-9922-018-23	XL Taper Stem, 18mm X 235mm	18	235
00-9922-019-13	XL Taper Stem, 19mm X 135mm	19	135
00-9922-019-18	XL Taper Stem, 19mm X 185mm	19	185
00-9922-019-23	XL Taper Stem, 19mm X 235mm	19	235
00-9922-020-13	XL Taper Stem, 20mm X 135mm	20	135
00-9922-020-18	XL Taper Stem, 20mm X 185mm	20	185
00-9922-020-23	XL Taper Stem, 20mm X 235mm	20	235
00-9922-021-13	XL Taper Stem, 21mm X 135mm	21	135
00-9922-021-18	XL Taper Stem, 21mm X 185mm	21	185
00-9922-021-23	XL Taper Stem, 21mm X 235mm	21	235
00-9922-022-13	XL Taper Stem, 22mm X 135mm	22	135
00-9922-022-18	XL Taper Stem, 22mm X 185mm	22	185
00-9922-022-23	XL Taper Stem, 22mm X 235mm	22	235
00-9922-023-18	XL Taper Stem, 23mm X 185mm	23	185
00-9922-023-23	XL Taper Stem, 23mm X 235mm	23	235
00-9922-024-18	XL Taper Stem, 24mm X 185mm	24	185
00-9922-024-23	XL Taper Stem, 24mm X 235mm	24	235

XL Porous Stems

Prod. No.	Description	E Stem Dia. (mm)	F Stem Length (mm)
00-9921-165-22	XL Porous Stem, 16.5 X 170mm, Straight	16.5	170
00-9921-165-32	XL Porous Stem, 16.5 X 170mm, Bowed	16.5	170
00-9921-165-33	XL Porous Stem, 16.5 X 220mm, Bowed	16.5	220
00-9921-165-34	XL Porous Stem, 16.5 X 260mm, Bowed	16.5	260
00-9921-180-22	XL Porous Stem, 18.0 X 170mm, Straight	18.0	170
00-9921-180-32	XL Porous Stem, 18.0 X 170mm, Bowed	18.0	170
00-9921-180-33	XL Porous Stem, 18.0 X 220mm, Bowed	18.0	220
00-9921-180-34	XL Porous Stem, 18.0 X 260mm, Bowed	18.0	260
00-9921-195-22	XL Porous Stem, 19.5 X 170mm, Straight	19.5	170
00-9921-195-32	XL Porous Stem, 19.5 X 170mm, Bowed	19.5	170
00-9921-195-33	XL Porous Stem, 19.5 X 220mm, Bowed	19.5	220
00-9921-195-34	XL Porous Stem, 19.5 X 260mm, Bowed	19.5	260
00-9921-210-22	XL Porous Stem, 21.0 X 170mm, Straight	21.0	170
00-9921-210-32	XL Porous Stem, 21.0 X 170mm, Bowed	21.0	170
00-9921-210-33	XL Porous Stem, 21.0 X 220mm, Bowed	21.0	220
00-9921-210-34	XL Porous Stem, 21.0 X 260mm, Bowed	21.0	260
00-9921-225-22	XL Porous Stem, 22.5 X 170mm, Straight	22.5	170
00-9921-225-32	XL Porous Stem, 22.5 X 170mm, Bowed	22.5	170
00-9921-225-33	XL Porous Stem, 22.5 X 220mm, Bowed	22.5	220
00-9921-225-34	XL Porous Stem, 22.5 X 260mm, Bowed	22.5	260
00-9921-240-22	XL Porous Stem, 24.0 X 170mm, Straight	24.0	170
00-9921-240-32	XL Porous Stem, 24.0 X 170mm, Bowed	24.0	170
00-9921-240-33	XL Porous Stem, 24.0 X 220mm, Bowed	24.0	220
00-9921-240-34	XL Porous Stem, 24.0 X 260mm, Bowed	24.0	260
00-9921-255-22	XL Porous Stem, 25.5 X 170mm, Straight	25.5	170
00-9921-255-32	XL Porous Stem, 25.5 X 170mm, Bowed	25.5	170
00-9921-255-33	XL Porous Stem, 25.5 X 220mm, Bowed	25.5	220
00-9921-255-34	XL Porous Stem, 25.5 X 260mm, Bowed	25.5	260

ZMR XL Hip

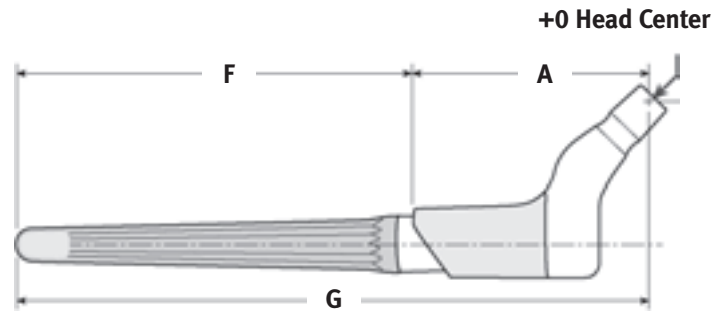
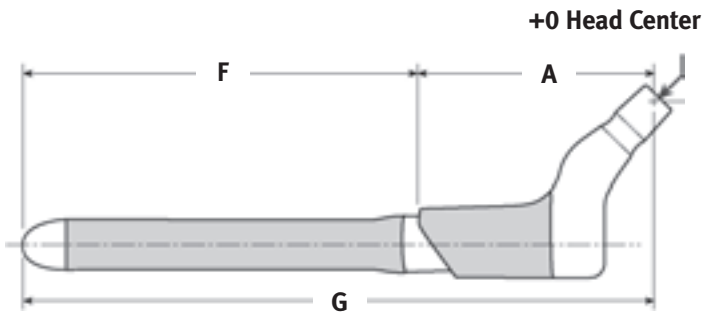

Assembled Implant Length

A Body Length (mm)	+	F Stem Length (mm)	=	G Implant Length (mm)
78		135		213
78		170		248
78		185		263
78		220		298
78		235		313
78		260		338
83		135		218
83		170		253
83		185		268
83		220		303
83		235		318
83		260		343
93		135		228
93		170		263
93		185		278
93		220		313
93		235		328
93		260		353
103		135		238
103		170		273
103		185		288
103		220		323
103		235		338
103		260		363

Porous Instrumentation*

Prod. No.	Description
00-9961-000-01	Porous Stem Provisional Add-on Set*
00-9961-000-02	Bowed Provisional Stem Set*
00-9961-000-03	Straight Provisional Stem Set*
00-9961-000-04	Macro Bowed Provisional Stem Set*
00-9975-000-06	Straight Reamer Set #1*
00-9975-000-07	Straight Reamer Set #2*
00-9975-000-11	Flexible Reamer Set*
00-9975-000-21	XL Porous Proximal Preparation Set*
00-9975-000-39	Proximal Preparation Instrument Set #1*
00-9975-000-40	Proximal Preparation Instrument Set #2*
00-9975-000-45	General Instrument Set*
00-9975-099-00	Case Lid

* Set includes case and contents without the 00-9975-099-00 Case Lid.
The Case Lid must be ordered separately.

† Requires Stem Impactor and Loose Assembly Sleeve.

Taper Instrumentation*

Prod. No.	Description
00-9975-000-22	XL Taper Proximal Preparation Set*
00-9975-000-23	XL Taper Stem Provisional Set*
00-9975-000-24	XL Distal Taper Reamer Set*
00-9975-000-45	General Instrument Set*
00-9975-099-00	Case Lid

* Set includes case and contents without the 00-9975-099-00 Case Lid.
The Case Lid must be ordered separately.

† Requires Stem Impactor and Loose Assembly Sleeve.

Compression Nut**

Prod. No.	Description
00-9982-099-02	Junction Nut**

** Compression nuts are also packed with distal stems.

References

1. Crowninshield RD, Maloney WJ, Wentz DH, et al. The role of proximal femoral support in stress development within hip prostheses. *Clin Orthop*. March 2004; (920): 176-180.
2. Data on file at Zimmer, Inc.

DISCLAIMER:

This documentation is intended exclusively for physicians and is not intended for laypersons. Information on the products and procedures contained in this document is of a general nature and does not represent and does not constitute medical advice or recommendations. Because this information does not purport to constitute any diagnostic or therapeutic statement with regard to any individual medical case, each patient must be examined and advised individually, and this document does not replace the need for such examination and/or advise in whole or in part.

Please refer to the package inserts for important product information, including, but not limited to, indications, contraindications, warnings, precautions, and adverse effects.

Contact your Zimmer representative or visit us at www.zimmer.com

The CE mark is valid only if it is also printed on the product label.

